

Ghost

For Cladding:

- indoor plasterboard
- exterior Fiber Cement siding panels
- mosaic or ceramic tiles
- stone finish
- wood



pag.4

For Cast Concrete

p.12

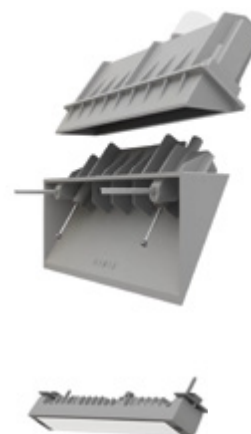

For Insulation panels

p.20



For Construction materials to be plastered

p.24



Exterior fiber cement siding panels (with anodised aluminium front panel)

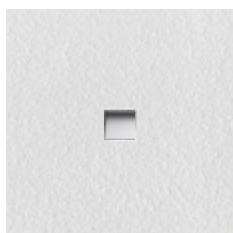

Microghost
L 68 H 68

Mosaic or Tiles (the front aperture is finished in the same material)

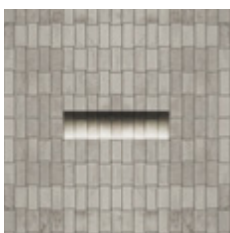

Ghost
L 240 H 68

Wood (with anodised aluminium front panel)

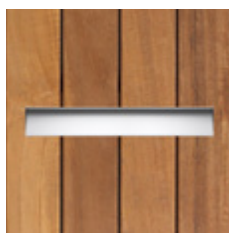

Ghost
L 430 H 68

Stone finish (the front aperture finished in the same material)



Ghost
L 810 H 68
L 1570 H 68
Continuous line

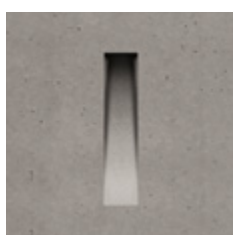

Ghost vertical
L 350 H 75

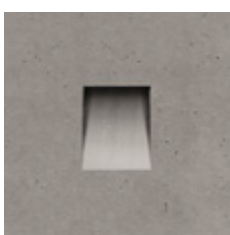

Minighost square
L 155 H 190

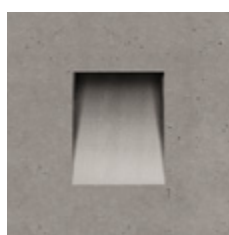

Ghost square
L 210 H 260



Microghost square
L 90 H 100

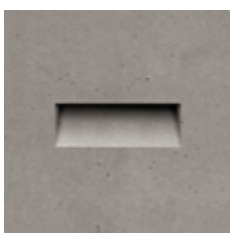

Ghost horizontal
L 290 H 100

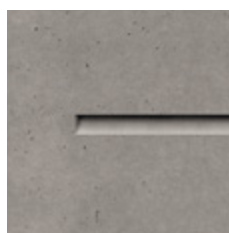

Ghost linear H 48
L 240
L 430
L 810
L 1570

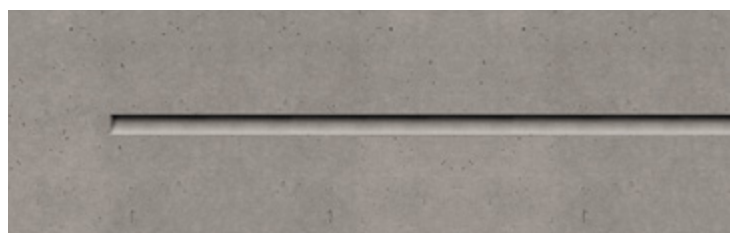

Ghost linear continuous line

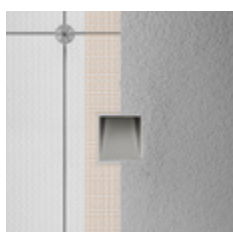

Microghost square
L 90 H 100

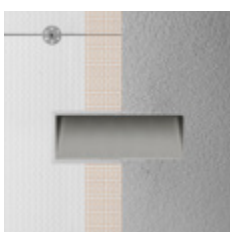

Ghost horizontal
L 290 H 100



Microghost square
L 90 H 100



Ghost horizontal
L 290 H 100



Ghost

for Cladding

Exterior fiber cement siding panels (with anodised aluminium front panel)

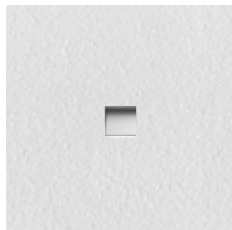

Stone finish (the front aperture finished in the same material)

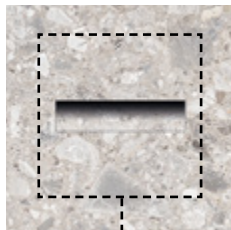

Wood (with anodised aluminium front panel)

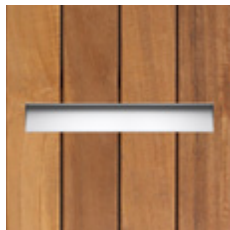

Mosaic or Tiles (the front aperture is finished in the same material)



Ghost with front aperture finished in the same material



Ghost with anodised aluminium front panel



Ghost continuous line application

Ghost for cladding or plasterboard is the most recent development of the range. It comes with an anodised aluminium recessed housing that can be finished in many different materials such as plasterboard, mosaic, ceramic tiles or stone finish.

The fixtures aperture has also been developed with a slanted front panel accessory in anodised aluminium that can be removed so to take different types of material finish, especially when the use of different materials may prove difficult when applying on the slanted aperture. Ghost has been developed so that it can be completely covered with the same material finish as the wall to totally integrate the fixture into the architecture and create discreet lighting effects.

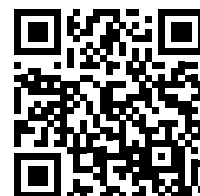

Ghost for Cladding



Ghost for cladding can be installed in plasterboard panels for indoors, exterior fiber cement siding panels, breeze blocks or other construction materials that require a surface finish. A fixture that has been developed to be totally integrated into the architecture. The slanted front aperture can either be in anodised aluminium or it can be finished with the same material finish as the wall. The front lip of the recessed housing and the aluminium sides of the front aperture will remain visible.

Procedure for Plasterboard or exterior fiber cement siding panels

1. Position the conduit for the electrical feed.
2. Fix the product to the plasterboard panel.
3. Cover the gaps between the panels with a mesh and plaster over.
4. Complete the surface finish
5. The fixture is supplied with a slanted front panel accessory in anodised aluminium. For indoor applications this panel can be removed and then finished in plasterboard; for outdoor applications we suggest to use this panel (a 19mm recess depth has been provided for the final finish if the panel is not used).
6. Once the plaster is dry you can fit the LED profile into the void.

This is the procedure for other walls built on site:

1. Cut away and position the conduit for the electrical feed;
2. Create a niche and recess the fixture housing and align correctly;
3. Cement the housing into the niche and use a gripping mesh to cover both the wall and the housing;

4. Cement the fixture into the wall, cut the gripping mesh around the fixtures aperture and continue with the finish by applying the relative material to the slanted aperture (19mm recess depth has been provided for the final finish if the panel is not used).

5. The fixture is supplied with an anodised aluminium front panel. You can decide to use this panel so to have a complete aperture in anodised aluminium or without so to render the aperture in the same material finish as the rest of the surface.

6. Once the cladding is dry you can fit the LED profile into the void.

MICROGHOST SQUARE

Requires a remote constant voltage driver.
Pre-wired luminaire with 6m of neoprene cable.

CLASS III 

GHOST LINEAR

Luminaire supplied with 6m of cable.

CLASS II 

Protection class

IP65

Mechanical resistance

IK 10

Leds 4000K CR180 versions are available on request.

24V DC versions available with surcharge for use with remote dimmable drivers not included.

**PATENT PENDING
REGISTERED DESIGN**



NOTE The aluminium front panel can eventually be painted (care of the installer) but never covered with other materials as this will obstruct the installation or removal of the lighting element.

For the latest technical information and luminaire updates with LED technology please refer to www.simes.it



Luminaire guide video

Microghost L 68 mm for Cladding



C.8330W

Housings in aluminium
+
Lighting element with MID-POWER LEDs
3000K CRI80 96lm
Rated luminaire luminous flux 67lm
Rated input power flux 1W **24V DC**

Requires a remote constant voltage driver

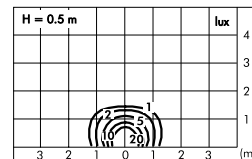

Ghost L 240 mm for Cladding

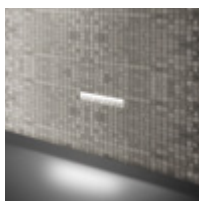
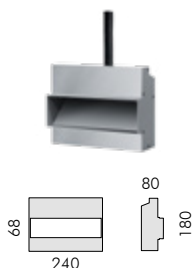

C.8334W

Housings in aluminium
+
Lighting element with MID-POWER LEDs
3000K CRI80 382lm
Rated luminaire luminous flux 266lm
Rated input power flux 4W
220V-240V AC 50/60Hz / DC Not Dimmable

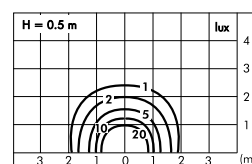

Ghost L 430 mm for Cladding

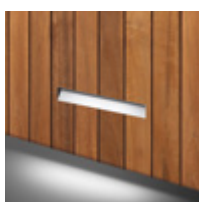
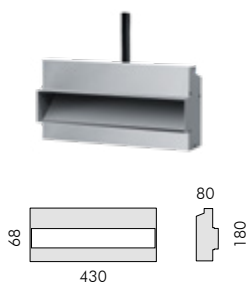

C.8336W

Housings in aluminium
+
Lighting element with MID-POWER LEDs
3000K CRI80 764lm
Rated luminaire luminous flux 532lm
Rated input power flux 7,5W
220V-240V AC 50/60Hz / DC Not Dimmable

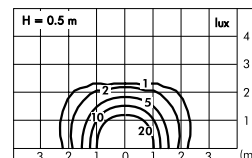

Ghost L 810 mm for Cladding

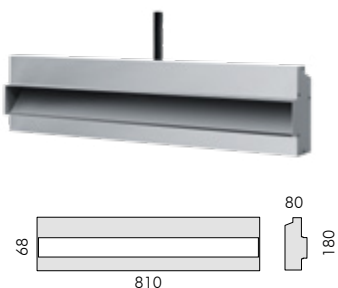

C.8338W

Housings in aluminium
+
Lighting element with MID-POWER LEDs
3000K CRI80 1528lm
Rated luminaire luminous flux 1044lm
Rated input power flux 14W
220V-240V AC 50/60Hz / DC Not Dimmable

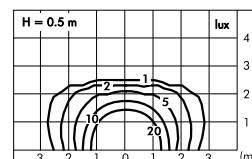

Ghost L 1570 mm for Cladding

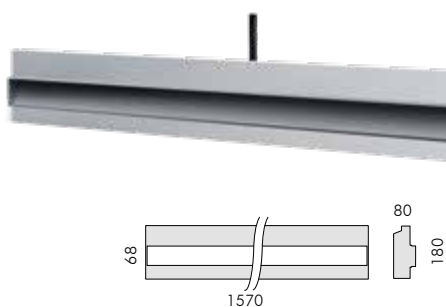

C.8340W

Housings in aluminium
+
Lighting element with MID-POWER LEDs
3000K CRI80 3056lm
Rated luminaire luminous flux 2077lm
Rated input power flux 28W
220V-240V AC 50/60Hz / DC Not Dimmable

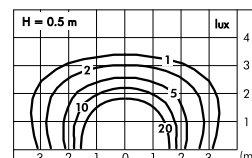

Ghost Continuous line for Cladding

Ghost for cladding can be connected to obtain continuous linear cavities, only for surface finish with mosaics, ceramic tiles and stone and only when the front aperture is finished in the same material (care of the installer). We do not suggest the use of anodized aluminum panel as the gap between each panel in the front aperture will be visible.

All Ghost Linear versions may be connected to obtain continuous linear cavities. To fix the appropriate number of articles to achieve the length desired it is recommended to start with multiples of the longest versions and subsequently with the shorter ones as end pieces.

Taking the four standard sizes available in the catalogue any situation can be solved with a maximum run-out of 23 cm. The run-out may be divided at the beginning and at the end of the wall as a free space between the final part of the wall and the luminous cavity (take into consideration at least 5 cm as a free space).

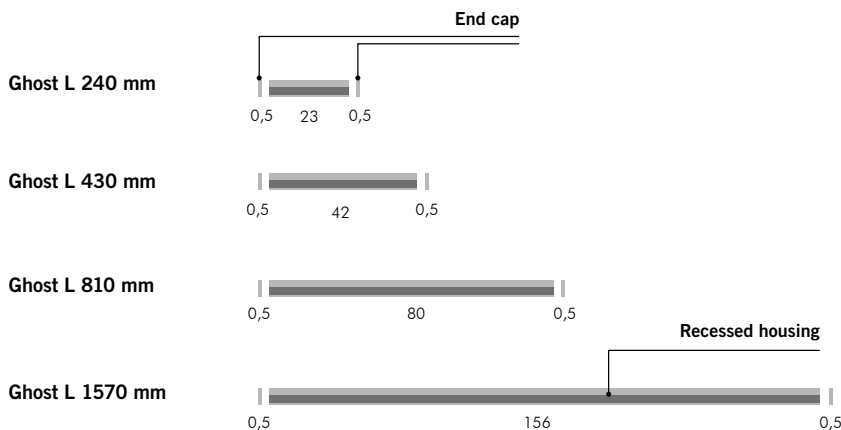

Example 1: WALL OF 354 cm

CONTINUOUS LINE FOR CLADDING of 336 cm + 9 cm gaps each end



- $0,5 \text{ cm (end cap)} + (156 \text{ cm} \times 2) + 23 \text{ cm (recessed housings)} + 0,5 \text{ cm (end cap)} = 336 \text{ cm}$
- $354 \text{ cm (wall length)} - 336 \text{ cm (total length of void)} = 18 \text{ cm (total clear gap)}$
- $18 \text{ cm} / 2 = 9 \text{ cm (deviation each end)}$

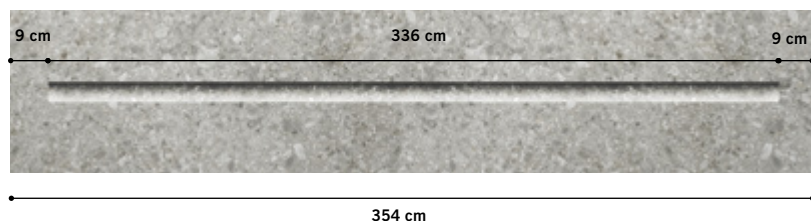

Example 2: WALL OF 603 cm

CONTINUOUS LINE FOR CLADDING of 591 cm + 6 cm gaps each end



- $0,5 \text{ cm (end cap)} + (156 \text{ cm} \times 3) + 80 \text{ cm} + 42 \text{ cm (recessed housings)} + 0,5 \text{ cm (end cap)} = 591 \text{ cm}$
- $603 \text{ cm (wall length)} - 591 \text{ cm (total length of void)} = 12 \text{ cm (total clear gap)}$
- $12 \text{ cm} / 2 = 6 \text{ cm (deviation each end)}$

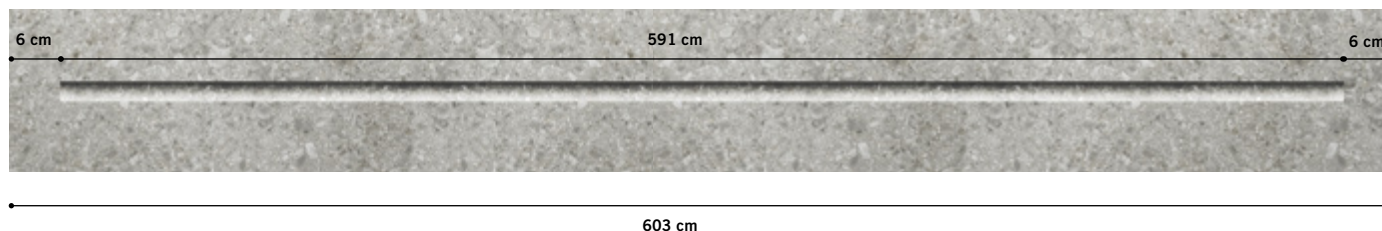



SCIENCE GALLERY

KING'S COLLEGE LONDON

SCIENCE GALLERY

H O O K

Ghost for Cladding with indoor plasterboard

The standard fitting is supplied with an anodised aluminum front panel to complete the housing. You can choose to keep it to finish the entire luminous void in aluminum, or take it off the inclined surface with the cladding material used for the wall (19 mm of recessing depth has been provided for the final finish). The front lip of the recessed housing and the aluminium sides of the front aperture will remain visible.

Anodised aluminum front panel included

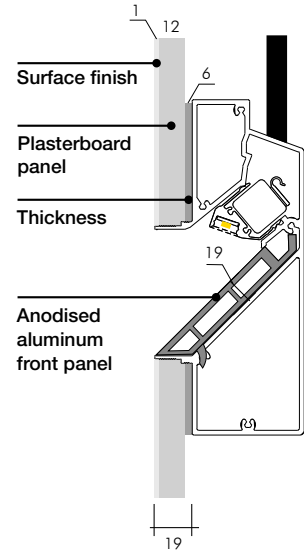

Plasterboard front panel care of the installer

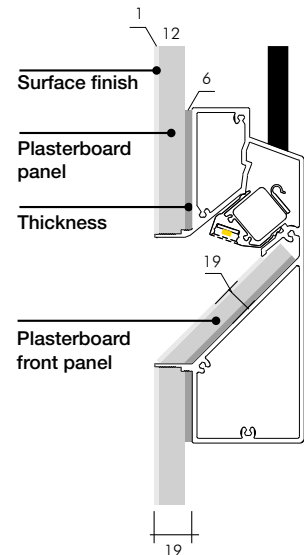
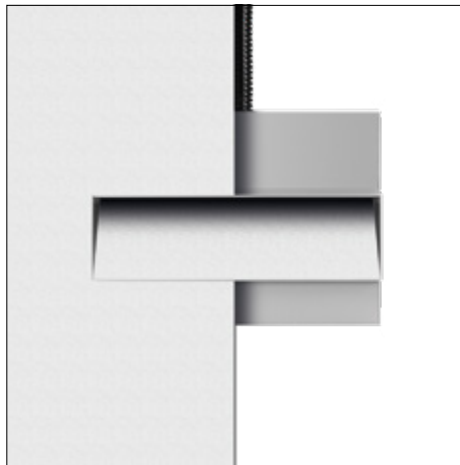
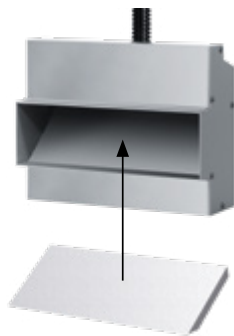

Ghost for Cladding with Exterior Fiber Cement siding panels (Aquapanel® type)

The standard fitting is supplied with an anodised aluminum front panel to complete the housing. For this type of application it is advisable to use the aluminium front panel accessory as an outdoor plaster finish inside the slanted aperture could prove difficult. The front lip of the recessed housing, the aluminium sides of the front aperture and the anodised aluminium front panel will remain visible.

Anodised aluminum Slide included

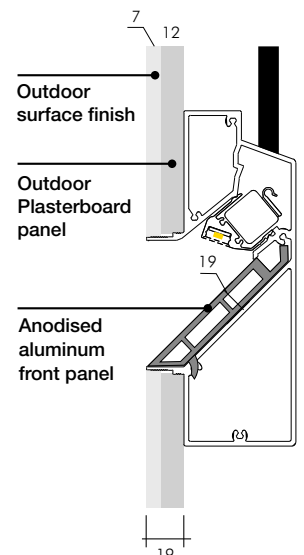
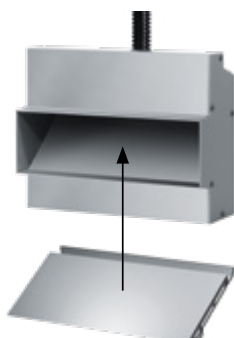

The standard fitting is supplied with an anodised aluminum front panel to complete the housing. You can choose to keep it to finish the entire luminous void in aluminum, or take it off the inclined surface with the cladding material used for the wall (19 mm of recessing depth has been provided for the final finish). The front lip of the recessed housing and the aluminium sides of the front aperture will remain visible.

Anodised aluminum front panel included

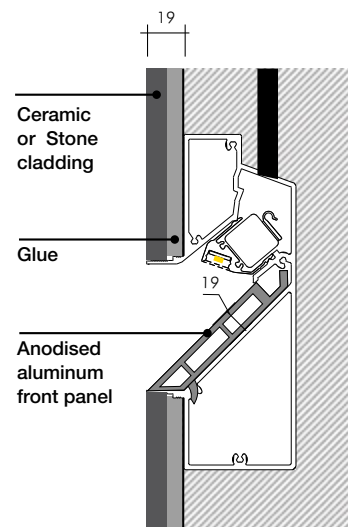
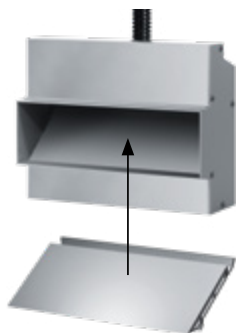

Ceramic or Stone front finish care of the installer

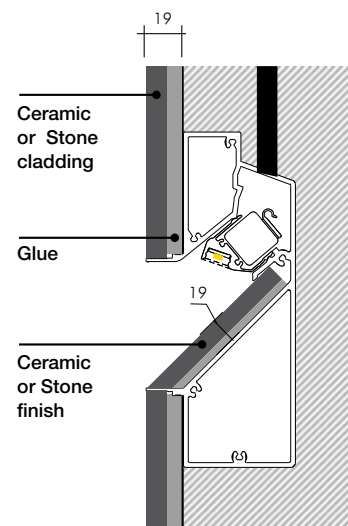

Ghost for Cladding with mosaic, ceramic tiles, stone finish

Ghost for cladding can be connected to obtain continuous linear cavities, only for surface finish with mosaics, ceramic tiles and stone and only when the front aperture is finished in the same material (care of the installer).

We do not suggest the use of anodized aluminum panel as the gap between each panel in the front aperture will be visible.





Ghost

for Cast concrete

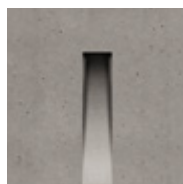

Design M.Sadler

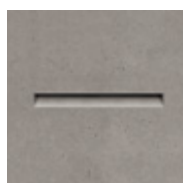
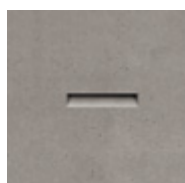
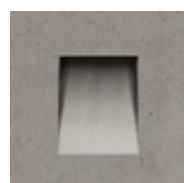

Ghost for cast concrete is a luminous void created through a specific recessed housing fixed to the shutters before casting. The LED engine is only installed when the concrete surrounding the housing is completely dry, filling the void with light.

"The light blade comes from the concrete. When it's off, it disappears. No artifice, just a void in the concrete with brutal and magic inspiration: actually a technical prodigy, directly cast into the concrete, the product of a sophisticated and invisible genius to fuse architecture and light in a natural way." M. Sadler



reddot award 2018
best of the best



Ghost Vertical



2016

Ghost Horizontal

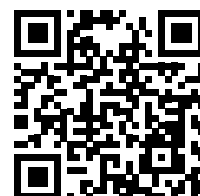

www.simes.it/ghost-castconcrete

Ghost for cast concrete



Ghost is a **lighting void** that is obtained from a polypropylene housing anchored to the retaining panels before pouring the concrete. Ghost is composed of two elements: the **housing** and the **lighting element**.

The housing is in polypropylene (in aluminium for LINEAR versions) and it consists of two complementary parts:
 - A jig (**1A**), which forms the housing, and is extracted together with the retaining panel after completing the casting and removing the anchor screws (**2**);
 - The housing (**1B**) that remains embedded inside the casting and houses the lighting element.

(The housing is supplied with bolts, locking system and stickers to be applied on the outside of the retaining panels so to secure a perfect alignment for multiple installations of each housing when pouring the concrete). The cavity will have the finish obtained directly from the concrete cast.

The **Lighting element (3)** in die cast aluminium is secured to the recessed casing (**1B**) with screws and remains completely hidden within the void.

GHOST HORIZONTAL
 Pre-wired luminaire with 0,3m neoprene cable and connector in the recessed box.
 CLASS I ⊕

GHOST VERTICAL
 Luminaire supplied with 6m of cable.
 CLASS I ⊕

MICROGHOST SQUARE
 Requires a remote constant voltage driver.
 Pre-wired luminaire with 6m of neoprene cable.
 CLASS III ⚡

MINIGHOST and GHOST SQUARE
 Pre-wired luminaire with 0,3m neoprene cable.
 CLASS I ⊕

GHOST LINEAR
 Luminaire supplied with 6m of cable.
 CLASS II □

Protection class
 IP65

Mechanical resistance
 IK 10

Leds 4000K CRI80 versions are available on request.
 24V DC versions available with surcharge for use with remote dimmable drivers not included.

PATENTED REGISTERED DESIGN

Finishing:
 Cast cement
 Suitable for reinforced concrete

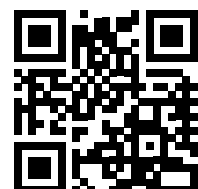
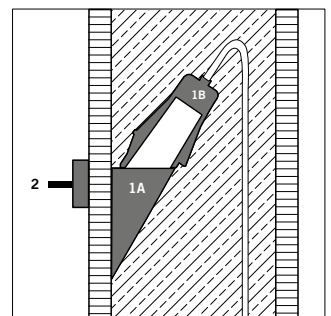
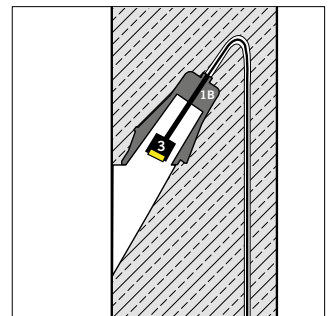

Luminaire guide video

Ghost Horizontal



C.8022W

2 housings in polypropylene with locking system
+
Lighting element with MID-POWER LEDs
3000K CRI80 880lm
Rated luminaire luminous flux 490lm
Rated input power flux 10W
220V-230V AC 50/60Hz Phase-cut dimmable

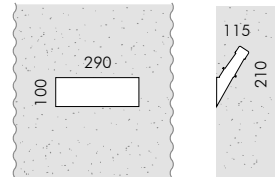
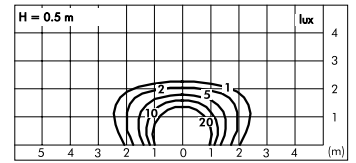

Ghost Vertical



C.8024W

2 housings in polypropylene with locking system
+
Lighting element with 1 COB LED
3000K CRI80 800lm
Rated luminaire luminous flux 612lm
Rated input power flux 7,6W
220V-240V AC 50/60Hz / DC Not Dimmable

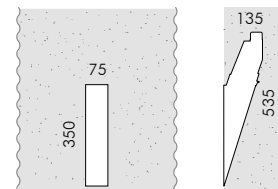
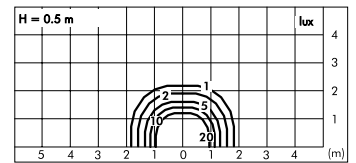

This luminaire is manufactured on site during the concrete casting of the wall with hand crafted procedures; therefore, small imperfections caused by the low accuracy of the casting, subsidence of the concrete surface, actual and future cracks, colour ripples and variations over time, will be deliberately present and they are a feature of the concrete, proving the hand-made manufacturing procedure.

For the latest technical information and luminaire updates with LED technology please refer to www.simes.it

Microghost Square



C.8030W

2 housings in polypropylene with locking system
+
Lighting element with MID-POWER LEDs
3000K CRI80 320lm
Rated luminaire luminous flux 240lm
Rated input power flux 4W **24V DC**

Requires a remote constant voltage driver

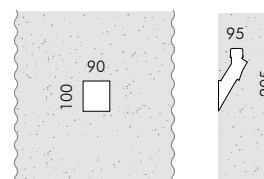
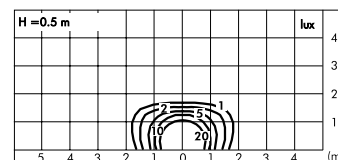

Minighost Square



C.8028W

2 housings in polypropylene with locking system
+
Lighting element with MID-POWER LEDs
3000K CRI80 490lm
Rated luminaire luminous flux 268lm
Rated input power flux 6W
220V-230V AC 50/60Hz Phase-cut dimmable

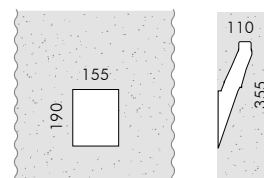
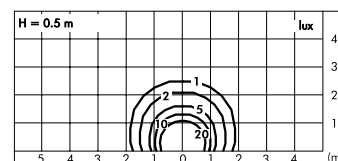

Ghost Square



C.8026W

2 housings in polypropylene with locking system
+
Lighting element with MID-POWER LEDs
3000K CRI80 1150lm
Rated luminaire luminous flux 550lm
Rated input power flux 12W
220V-230V AC 50/60Hz Phase-cut dimmable

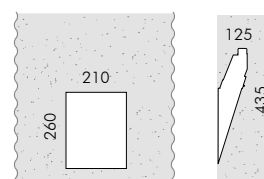
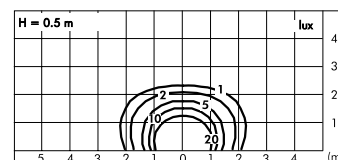



Ghost Linear L 240mm



C.8034W

2 housings in aluminium with locking system
+
Lighting element with MID-POWER LEDs
3000K CRI80 382lm
Rated luminaire luminous flux 266lm
Rated input power flux 4W
220V-240V AC 50/60Hz / DC Not Dimmable

Accessory drilling jig C.8033
Template for drilling *

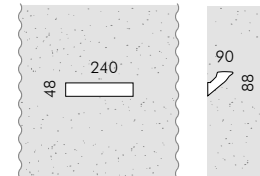
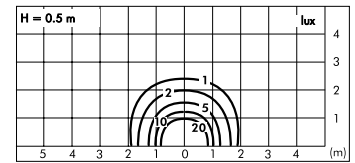

Ghost Linear L 430mm



C.8036W

2 housings in aluminium with locking system
+
Lighting element with MID-POWER LEDs
3000K CRI80 764lm
Rated luminaire luminous flux 532lm
Rated input power flux 7,5W
220V-240V AC 50/60Hz / DC Not Dimmable

Accessory drilling jig C.8035
Template for drilling *

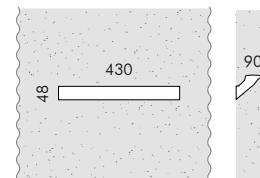
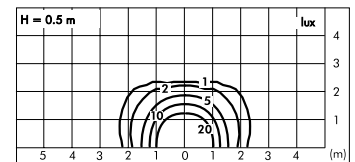

Ghost Linear L 810mm



C.8038W

2 housings in aluminium with locking system
+
Lighting element with MID-POWER LEDs
3000K CRI80 1528lm
Rated luminaire luminous flux 1044lm
Rated input power flux 14W
220V-240V AC 50/60Hz / DC Not Dimmable

Accessory drilling jig C.8037
Template for drilling *

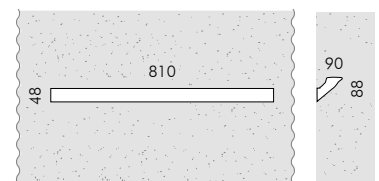
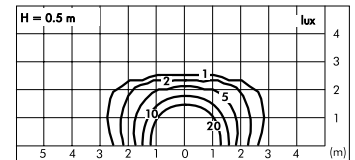

Ghost Linear L 1570mm



C.8040W

2 housings in aluminium with locking system
+
Lighting element with MID-POWER LEDs
3000K CRI80 3056lm
Rated luminaire luminous flux 2077lm
Rated input power flux 28W
220V-240V AC 50/60Hz / DC Not Dimmable

Accessory drilling jig C.8039
Template for drilling *

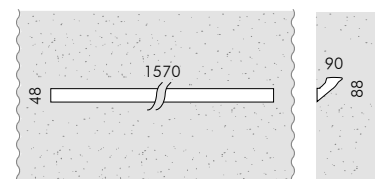
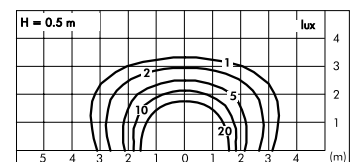

* The template for drilling facilitates the alignment of the recessed profile of Ghost Continuous Line. You require only one template for each size which can be used again.

“Running” GHOST LINEAR CONTINUOUS LINE

All Ghost Linear versions may be connected to obtain continuous linear cavities. To fix the appropriate number of articles to achieve the length desired it is recommended to start with multiples of the longest versions and subsequently with the shorter ones as end pieces.

Taking the four standard sizes available in the catalogue any situation can be solved with a maximum run-out of 22 cm. The run-out may be divided at the beginning and at the end of the wall as a free space between the final part of the wall and the luminous cavity (take into consideration at least 5 cm as a free space).

To facilitate the operation use a drilling template available as an accessory for every Ghost Linear version. For each version used one only drilling template is required.

Consult a Structural Engineering company to have an appropriate framework and thickness of the wall calculated. Please keep in mind that the Ghost Linear in Continuous Line represents a linear continuous cavity of 9 cm deep.

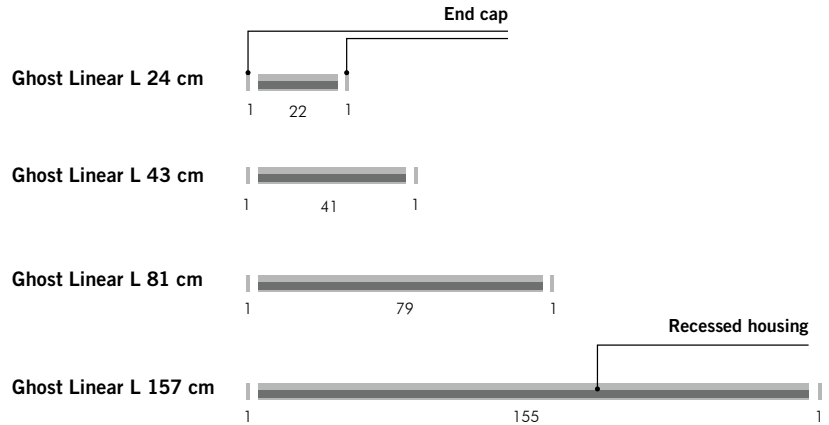

Example 1: WALL OF 344 cm

Continuous Ghost Linear of 334 cm + 5 cm gaps each end

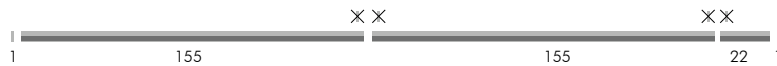

- 1 cm (end cap) + (155 cm x 2) + 22 cm (recessed housings) + 1 cm (end cap) = 334 cm
- 344 cm (wall length) - 334 cm (total length of void) = 10 cm (total clear gap)
- 10 cm / 2 = 5 cm (deviation each end)

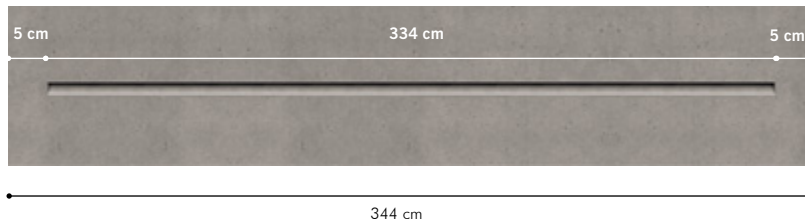

Example 2: WALL OF 603 cm

Continuous Ghost Linear of 587 cm + 8 cm gaps each end

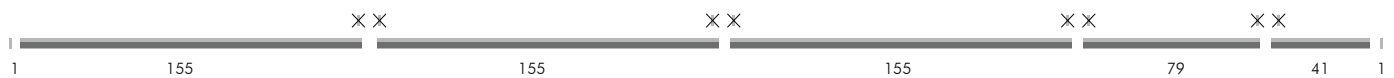

- 1 cm (end cap) + (155 cm x 3) + 79 cm + 41 cm (recessed housings) + 1 cm (end cap) = 587 cm
- 603 cm (wall length) - 587 cm (total length of void) = 16 cm (total clear gap)
- 16 cm / 2 = 8 cm (deviation each end)

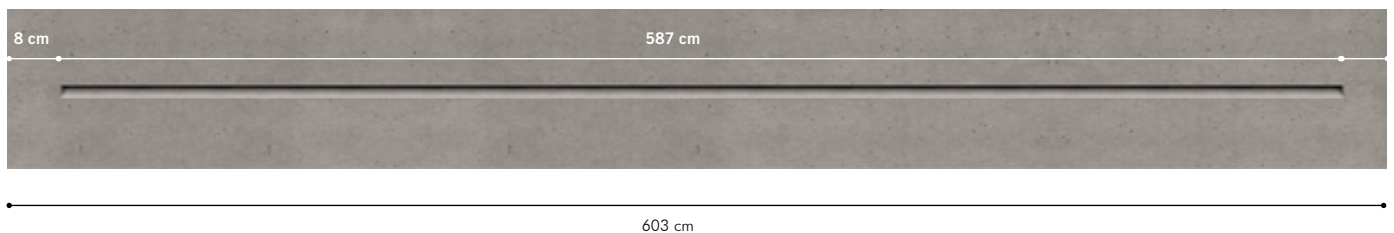

Luminaire guide video



Ghost

for Insulation panels

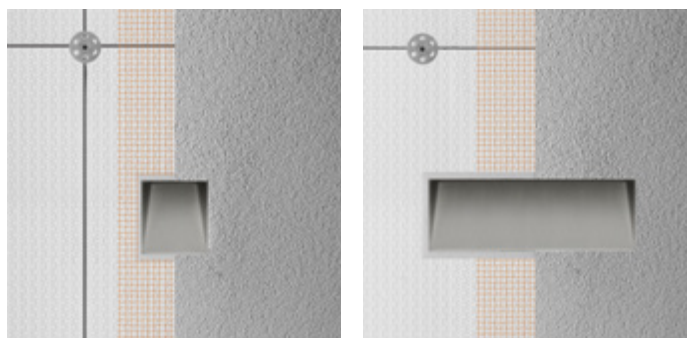

Ghost for insulation panels is a wall mounted signal lighting fixture. The luminous housing is installed together with the other insulating panels of polystyrene. In this way the light is completely integrated in the insulated "shell" of the architecture without jeopardizing the thermal insulation and therefore maintain the energy efficiency rating of the building.



Ghost for insulation panel

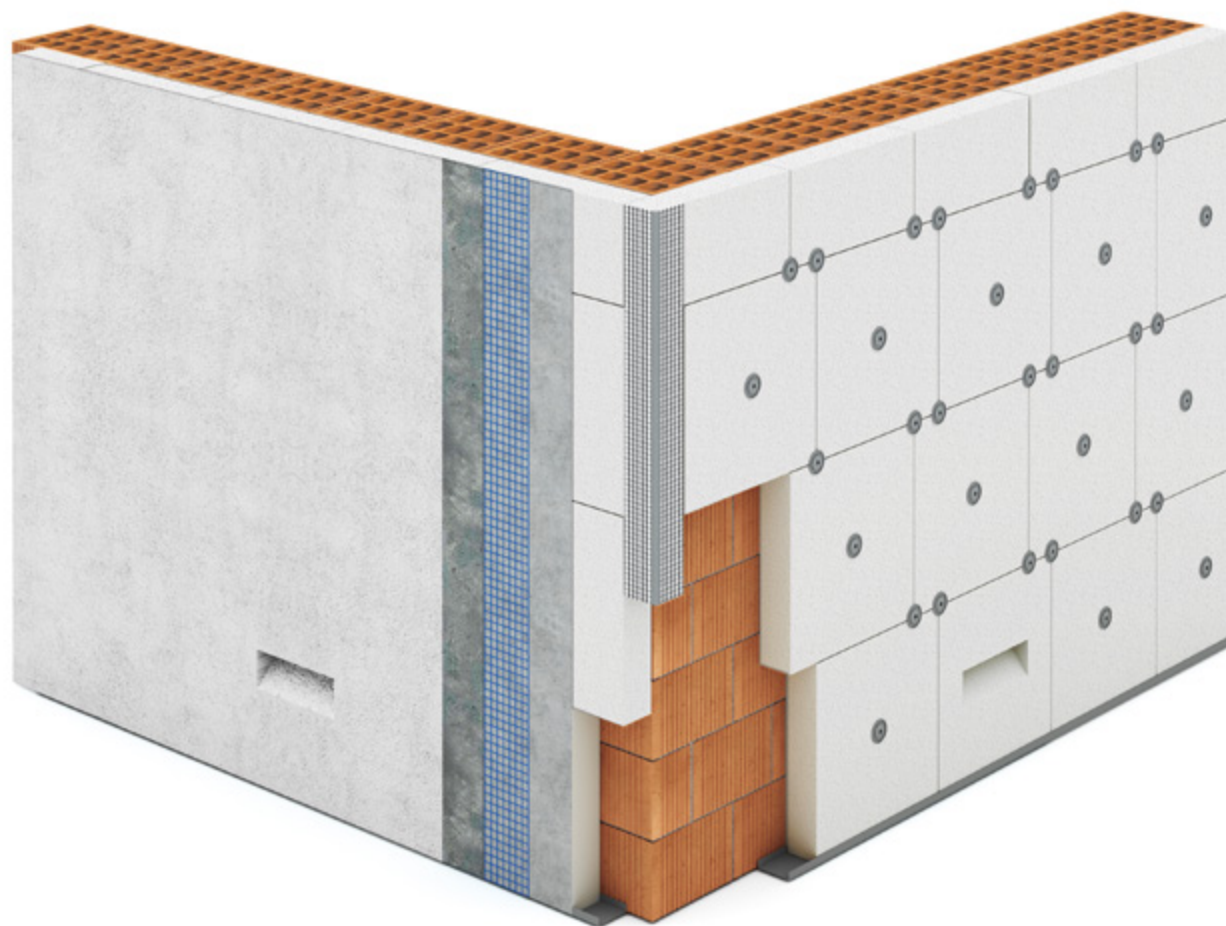

Ghost for insulation panel may be installed inside the exterior insulating panel. The degree of insulation of the house will stay unchanged for it is manufactured of the same type of polystyrene insulation.

Attention should be paid though to the positioning of the corrugated tube for mains electrical connection.

The height of Ghost for insulation panel has been designed to take on standard AED35 (50cm) insulating blocks while the thickness (10cm) facilitates the integration in insulating panels with the same or greater thickness. The cavity is pre-finished and ready for painting.

After installation the finish of the wall will proceed as usual:

1. Lay the grid, first levelling;
2. Carve the grid at the Ghost's cavity;
3. Second levelling and possible whitening;
4. At the end of the work install the lighting body.

MICROGHOST SQUARE

Requires a remote constant voltage driver. Pre-wired luminaire with 6m of neoprene cable.

CLASS III ⚡

GHOST HORIZONTAL

Pre-wired luminaire with 0,3m neoprene cable and connector in the recessed box.

CLASS I ⚡

Protection class

IP65

Mechanical resistance

IK 10

Leds 4000K CR180 versions are available on request.

24V DC versions available with surcharge for use with remote dimmable drivers not included.

**PATENT PENDING
REGISTERED DESIGN**

For the latest technical information and luminaire updates with LED technology please refer to www.simes.it



Luminaire guide video

Microghost Square for insulation panel

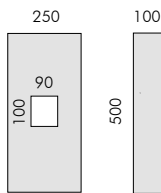
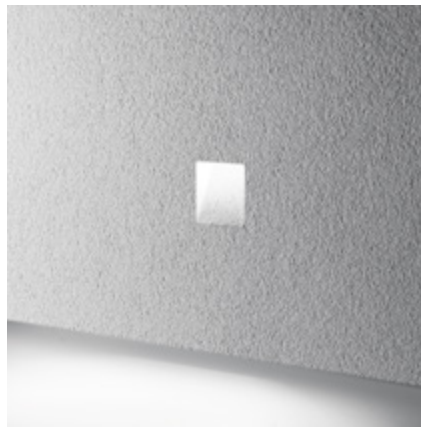

C.8130W

AE D35 polystyrene block with housings in polypropylene
 +
 Lighting element with MID-POWER LEDs
3000K CRI80 320lm
 Rated luminaire luminous flux 240lm
 Rated input power flux 4W **24V DC**

Requires a remote constant voltage driver

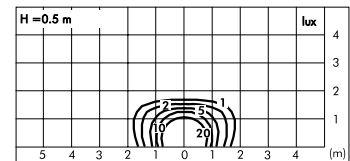

Ghost Horizontal for insulation panel

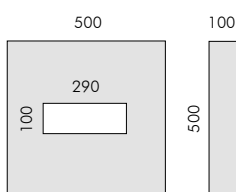
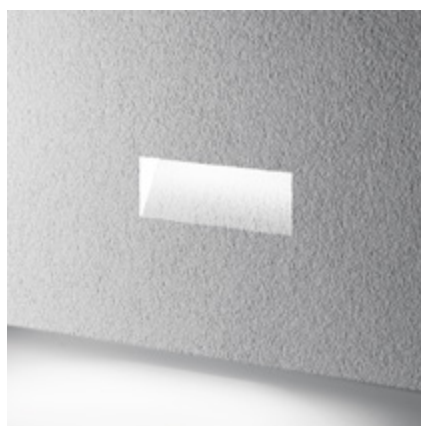

C.8122W

AE D35 polystyrene block with housings in polypropylene
 +
 Lighting element with MID-POWER LEDs **3000K**
 CRI80 880lm
 Rated luminaire luminous flux 490lm
 Rated input power flux 10W
 220V-230V AC 50/60Hz Phase-cut dimmable

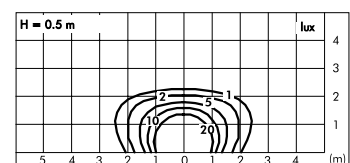



Ghost

for Construction materials with plaster finish

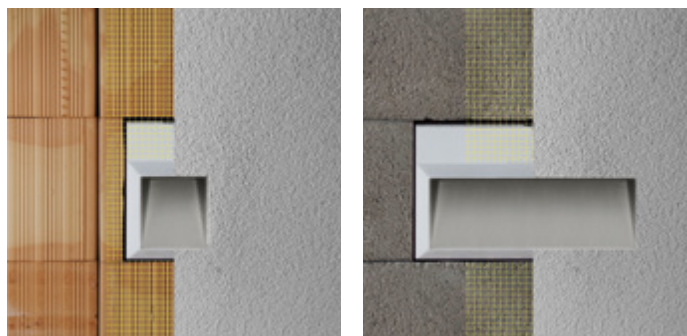

Ghost for construction materials is a further development of the Ghost range that allows to create lit voids into walls built from any material that require a plaster finish. The special recessed housing protrudes by 15mm so to consider the various layers of plaster so to give a perfect flush finish. The fixtures inclined aperture can be painted and is therefore completely integrated into the architecture.



Ghost for construction materials with plaster finish

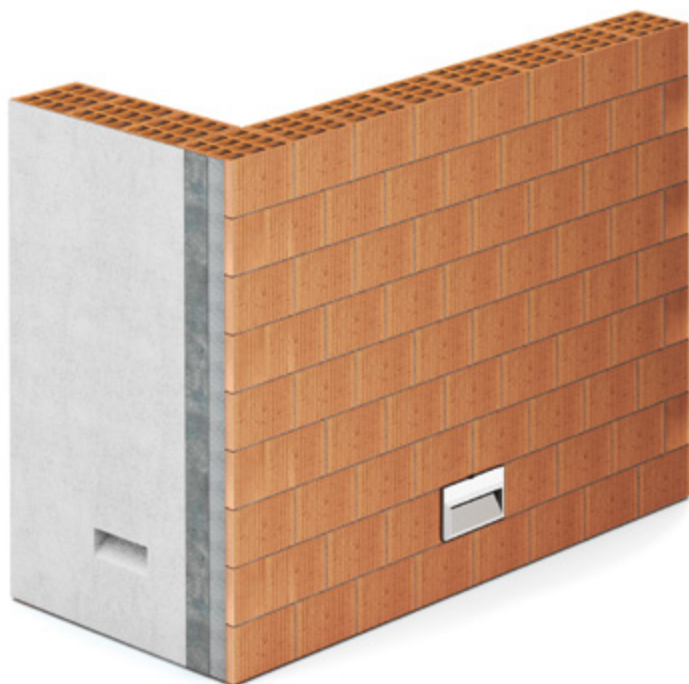

**Example 1
WALL IN CLAY
BLOCKS**



**Example 2
WALL IN BREEZE
BLOCKS**

Ghost for breeze block application is easily applied in walls made of perforated bricks or cement conglomerate. The luminaire is designed to be wall mounted and completely integrated with the architecture of which it will take over the finish. The cavity is pre-finished and ready for painting.

The procedure is as follows:

1. Plan the positioning of the corrugated tube for mains electrical connection;
2. Make a niche to insert the Ghost polystyrene block, paying attention to its aligning;
3. Lay the fixative grid that connects the cement conglomerate wall to the Ghost's polystyrene block;
4. Enclose the luminaire in the wall, cut the grid at the Ghost's cavity and finish off;
5. Once the work is finished, the luminaire may be installed.

MICROGHOST SQUARE
Requires a remote constant voltage driver.
Pre-wired luminaire with 6m of neoprene cable.

CLASS III 

GHOST HORIZONTAL
Pre-wired luminaire with 0,3m neoprene cable and connector in the recessed box.

CLASS I 

Protection class

IP65

Mechanical resistance

IK 10

Leds 4000K CRI80 versions are available on request.
24V DC versions available with surcharge for use with remote dimmable drivers not included.

**PATENT PENDING
REGISTERED DESIGN**

For the latest technical information and luminaire updates with LED technology please refer to www.simes.it



Luminaire guide video

Microghost Square

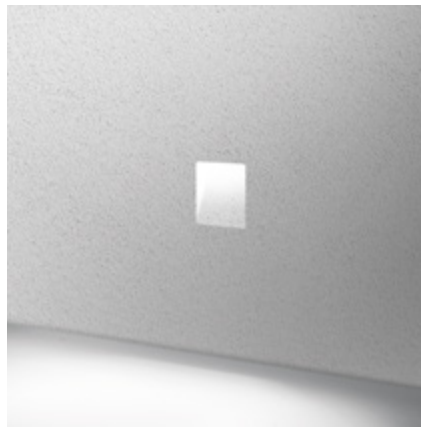
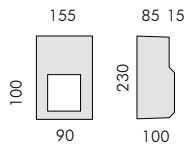

C.8230W

AE D35 polystyrene block with housings in polypropylene
+
Lighting element with MID-POWER LEDs
3000K CRI80 320lm
Rated luminaire luminous flux 240lm
Rated input power flux 4W **24V DC**

Requires a remote constant voltage driver

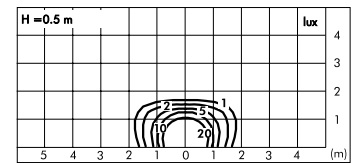

Ghost Horizontal

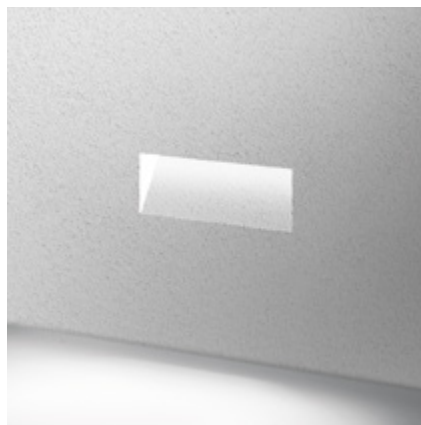
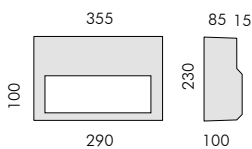

C.8222W

AE D35 polystyrene block with housings in polypropylene
+
Lighting element with MID-POWER LEDs
3000K CRI80 880lm
Rated luminaire luminous flux 490lm
Rated input power flux 10W
220V-230V AC 50/60Hz Phase-cut dimmable

